

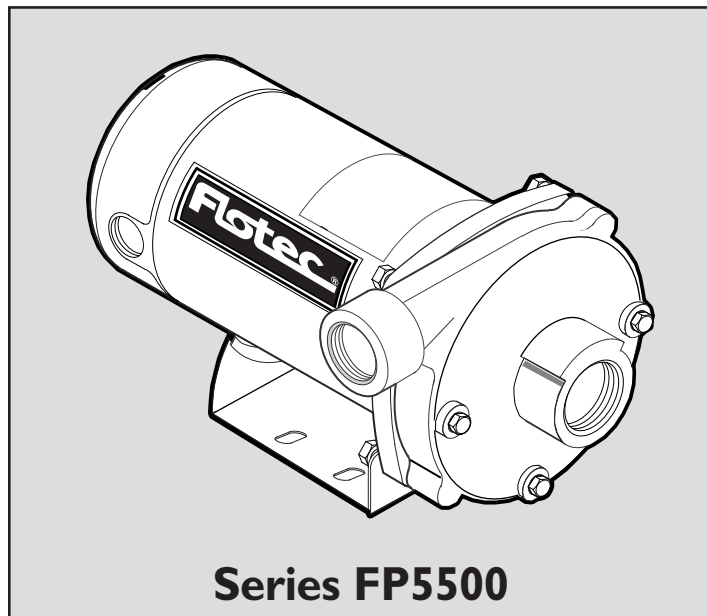

OWNER'S MANUAL
Centrifugal Pumps

P.O. Box 342, Delavan, WI 53115
Phone: 1-800-365-6832
Fax: 1-800-526-3757
E-Mail: info@flotecwater.com
Web Site: <http://www.flotecwater.com>



Water
is Our
Business®

Installation/Operation/Parts

*For further operating, installation,
or maintenance assistance:*

Call 1-800-365-6832

English Pages 2-7

READ AND FOLLOW SAFETY INSTRUCTIONS!

⚠ This is the safety alert symbol. When you see this symbol on your pump or in this manual, look for one of the following signal words and be alert to the potential for personal injury:

⚠ DANGER warns about hazards that **will** cause serious personal injury, death or major property damage if ignored.

⚠ WARNING warns about hazards that **can** cause serious personal injury, death or major property damage if ignored.

⚠ CAUTION warns about hazards that **will** or **can** cause minor personal injury or property damage if ignored.

The label **NOTICE** indicates special instructions which are important but not related to hazards.

Carefully read and follow all safety instructions in this manual and on pump.

Keep safety labels in good condition.

Replace missing or damaged safety labels.

ELECTRICAL SAFETY

⚠ WARNING Capacitor voltage may be hazardous.

To discharge motor capacitor, hold insulated handle screwdriver **BY THE HANDLE** and short capacitor terminals together. Do not touch metal screwdriver blade or capacitor terminals. If in doubt, consult a qualified electrician.

⚠ WARNING



Hazardous voltage. Can shock, burn, or cause death.

Ground pump before connecting to power supply. Disconnect power before working on pump, motor or tank.

⚠ Wire motor for correct voltage. See “Electrical” section of this manual and motor nameplate.

⚠ Ground motor before connecting to power supply.

⚠ Meet National Electrical Code, Canadian Electrical Code, and local codes for all wiring.

⚠ Follow wiring instructions in this manual when connecting motor to power lines.

GENERAL SAFETY

⚠ CAUTION **Do not touch an operating motor.** Modern motors are designed to operate at high temperatures. To avoid burns when servicing pump, allow it to cool for 20 minutes after shut-down before handling.

Do not allow pump or any system component to freeze. To do so will void warranty.

Pump water only with this pump.

Periodically inspect pump and system components.

Wear safety glasses at all times when working on pumps.

Keep work area clean, uncluttered and properly lighted; store properly all unused tools and equipment.

Keep visitors at a safe distance from the work areas.

Maximum pressure on shaft seal when pump is not running must be less than 75 PSI (517kPa) or seal may leak.

⚠ WARNING **Pump body may explode if used as a booster pump unless relief valve capable of passing full pump flow at 125 PSI (862 kPa) is installed.**

Thank you for purchasing a top quality, factory tested pump.

	Page
General Safety	2
Warranty	3
Installation	4
Electrical	5,6
Troubleshooting	7
Repair Parts	7

ATTACH ORIGINAL RECEIPT HERE FOR WARRANTY CONSIDERATION.

Flotec Limited Warranty

FLOTEC warrants to the original consumer purchaser ("Purchaser") of its products that they are free from defects in material or workmanship.

If within twelve (12) months from the date of the original consumer purchase any such product shall prove to be defective, it shall be repaired or replaced at FLOTEC's option, subject to the terms and conditions set forth below. Your original receipt of purchase is required to determine warranty eligibility.

Exceptions to the Twelve (12) Month Warranty

Ninety (90) Day Warranty:

If within ninety (90) days from original consumer purchase any Drill Pump, Pitcher Pump, or In-Line Water Filter Cartridge shall prove to be defective, it shall be replaced, subject to the terms set forth below.

Two (2) Year Warranty:

If within two (2) years from original consumer purchase any 1/3 HP Submersible Sump Pump or Model FP2800DCC shall prove to be defective, it shall be repaired or replaced at FLOTEC's option, subject to the terms and conditions set forth below.

Three (3) Year Warranty:

If within three (3) years from original consumer purchase any 4" Submersible Well Pump, or 1/2 HP Submersible Sump Pump, shall prove to be defective, it shall be repaired or replaced at FLOTEC's option, subject to the terms and conditions set forth below.

Four (4) Year Warranty:

If within four (4) years from original consumer purchase any FLOODMATE™ 7000 or IRONMATE™ Submersible Sump Pump shall prove to be defective, it shall be repaired or replaced at FLOTEC's option, subject to the terms and conditions set forth below.

Five (5) Year Warranty:

If within five (5) years from original consumer purchase any Pre-Charge water system tank shall prove to be defective, it shall be repaired or replaced at FLOTEC's option, subject to the terms and conditions set forth below.

General Terms and Conditions

Purchaser must pay all labor and shipping charges necessary to replace product covered by this warranty. This warranty shall not apply to acts of God, nor shall it apply to products which, in the sole judgement of FLOTEC, have been subject to negligence, abuse, accident, misapplication, tampering, alteration; nor due to improper installation, operation, maintenance or storage; nor to other than normal application, use or service, including but not limited to, operational failures caused by corrosion, rust or other foreign materials in the system, or operation at pressures in excess of recommended maximums.

Requests for service under this warranty shall be made by returning the defective product to the Retail outlet or to FLOTEC as soon as possible after the discovery of any alleged defect. FLOTEC will subsequently take corrective action as promptly as reasonably possible. No requests for service under this warranty will be accepted if received more than 30 days after the term of the warranty.

This warranty sets forth FLOTEC's sole obligation and purchaser's exclusive remedy for defective products.

FLOTEC SHALL NOT BE LIABLE FOR ANY CONSEQUENTIAL, INCIDENTAL, OR CONTINGENT DAMAGES WHATSOEVER.

THE FOREGOING WARRANTIES ARE EXCLUSIVE AND IN LIEU OF ALL OTHER EXPRESS WARRANTIES. IMPLIED WARRANTIES, INCLUDING BUT NOT LIMITED TO THE IMPLIED WARRANTIES OF MERCHANTABILITY AND FITNESS FOR A PARTICULAR PURPOSE, SHALL NOT EXTEND BEYOND THE DURATION OF THE APPLICABLE EXPRESS WARRANTIES PROVIDED HEREIN.

Some states do not allow the exclusion or limitation of incidental or consequential damages or limitations on how long an implied warranty lasts, so the above limitations or exclusions may not apply to you. This warranty gives you specific legal rights and you may also have other rights which vary from state to state.

FLOTEC • P.O. Box 342 • Delavan, WI U.S.A. 53115

Phone: 1-800-365-6832 • Fax: 1-800-526-3757

E-Mail: info@flotecwater.com • Web Site: <http://www.flotecwater.com>

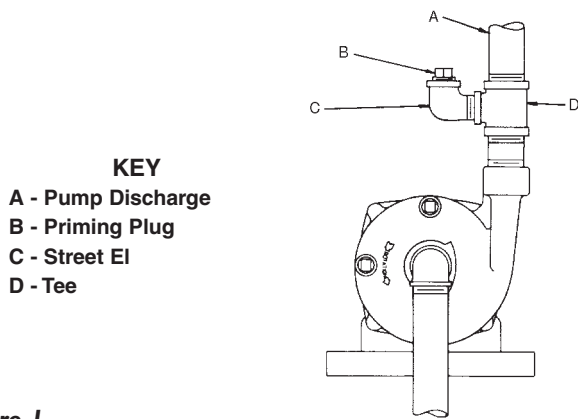

- KEY**
A - Pump Discharge
B - Priming Plug
C - Street El
D - Tee

Figure 1

PIPING

Both suction and discharge piping should be independently supported at a point near the pump to avoid strains being placed on the pump. Start all piping at pump to avoid strains left by a gap.

It is advisable to increase the size of both suction and discharge piping at the pump if any appreciable run of pipe is required. Never use a smaller suction pipe than the suction connection on the pump. Use a pipe wrench to hold the suction and discharge bosses of the pump while making up the piping, to avoid putting excess strain on the pump.

SUCTION PIPE

The suction pipe must be kept free from air leaks. Any horizontal run of suction piping must have a gradual upslope towards the pump. Avoid any fittings which may cause an air trap. A foot valve should be installed to prevent loss of pump prime.

DISCHARGE PIPING

A gate valve and union should be installed in the discharge line. For removal of the pump for service, close the gate valve, and disconnect the union.

PRIMING THE PUMP

Prime pump by filling both the pump and suction line completely with water thru the priming tee. Replace

priming plug and start pump. If water is not pumped immediately it is because all the air has not been evacuated. Stop pump and reprime, following instructions above. When used with vertical discharge, the vent plug at the top should be loosened to evacuate air which is trapped inside the volute. When volute is completely filled with water, tighten vent plug.

CAUTION NEVER run pump dry. Running pump without water may cause pump to overheat, damaging seal and possibly causing burns to persons handling pump. Fill pump with water before starting.

WARNING NEVER run pump against closed discharge. To do so can boil water inside pump, causing hazardous pressure in unit, risk of explosion and possibly scalding persons handling pump.

CAUTION Motor normally operates at high temperature and will be too hot to touch. It is protected from heat damage during operation by an automatic internal cutoff switch. Before handling pump or motor, stop motor and allow it to cool for 20 minutes.

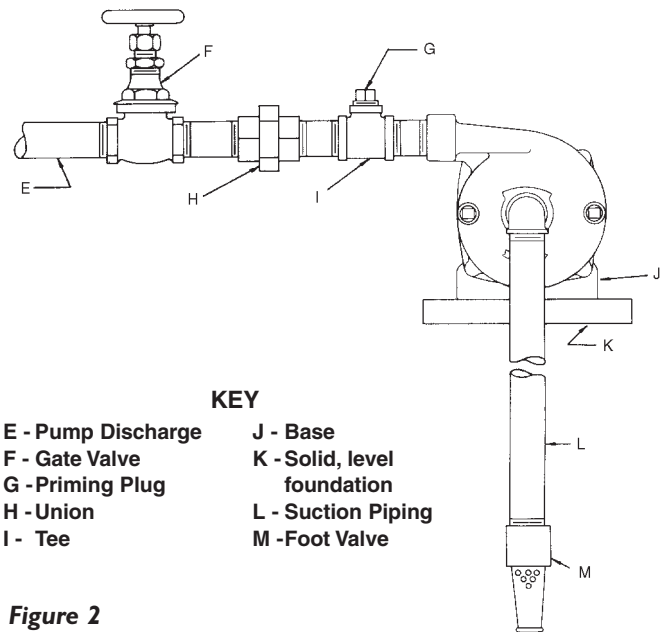

- KEY**
E - Pump Discharge
F - Gate Valve
G - Priming Plug
H - Union
I - Tee
J - Base
K - Solid, level foundation
L - Suction Piping
M - Foot Valve

Figure 2

PERFORMANCE

Model	HP	Voltage	Inlet	Discharge	Performance in GPM at Discharge Pressure Shown							
					25	30	35	40	45	50	55	Max PSI
FP5512	1/2	115/230	1-1/4"	1"	22	13	2	-	-	-	-	36
FP5522	3/4	115/230	1-1/4"	1"	31	25	21	13	-	-	-	43
FP5532	1	115/230	1-1/4"	1"	47	40	35	29	17	-	-	49
FP5542	1-1/2	115/230	1-1/4"	1"	59	52	47	40	30	15	-	51
FP5552	2	230	1-1/2"	1-1/4"	68	62	54	48	38	29	7	57

Connection diagram for dual voltage, single-phase motors. Your dual-voltage motor's terminal board (under the motor end cover) will match one of the diagrams below. Follow that diagram if necessary to convert motor to 115 Volt power.

Connect power supply wires to L1 and L2. For 3-phase motors, or if motor does not match these pictures, follow the connection diagram on the motor nameplate.

The motor is set for 230 volts when shipped.

To change the motor to use 115 volts:

1. Turn off power
2. Remove the back motor cover.

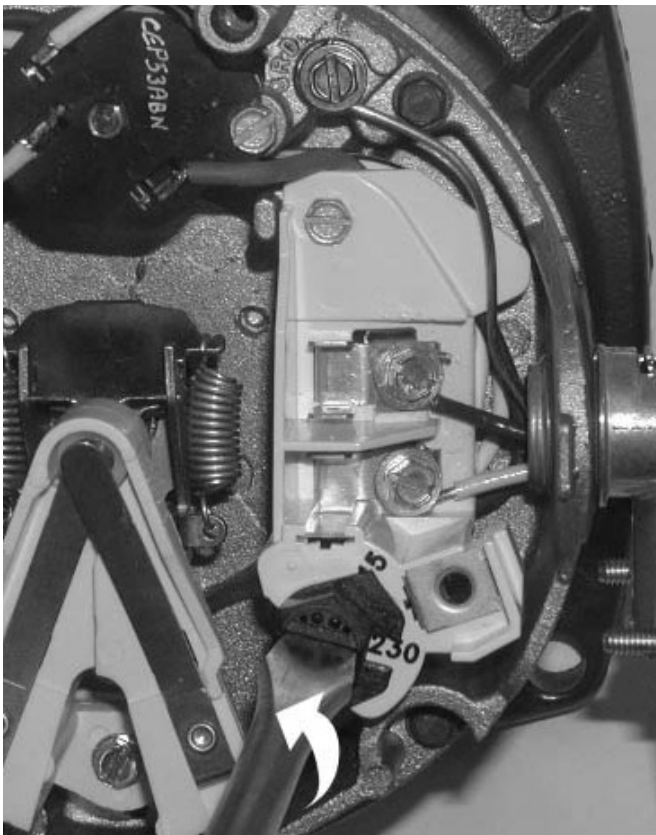

Figure 3 – Changing the Voltage Setting

3. Use a screwdriver or 1/2" wrench and turn the voltage selector dial counterclockwise until 115 shows in the dial opening.

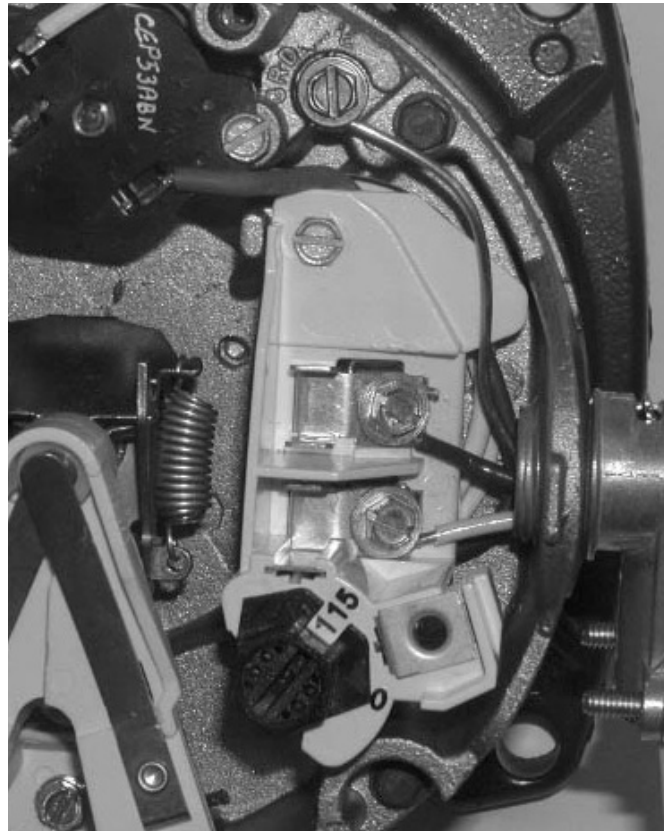

Figure 4 – Motor Set for 115 Volt Operation

4. Reinstall the motor cover.

⚠ WARNING Hazardous voltage. Can shock, burn, or cause death. Disconnect power to motor before working on pump or motor. Ground motor before connecting to power supply.

WIRING

- ⚠ Ground motor before connecting to electrical power supply. Failure to ground motor can cause severe or fatal electrical shock hazard.
- ⚠ Do not ground to a gas supply line.
- ⚠ To avoid dangerous or fatal electrical shock, turn OFF power to motor before working on electrical connections.
- ⚠ Supply voltage must be within $\pm 10\%$ of nameplate voltage. Incorrect voltage can cause fire or damage motor and voids warranty. If in doubt consult a licensed electrician.

⚠ Use wire size specified in Wiring Chart (Page 6). If possible, connect pump to a separate branch circuit with no other appliances on it.

⚠ Wire motor according to diagram on motor nameplate. If nameplate diagram differs from diagrams above, follow nameplate diagram.

- Step 1. Install, ground, wire and maintain this pump in accordance with electrical code requirements. Consult your local building inspector for information about codes.
- Step 2. Provide a correctly fused disconnect switch for protection while working on motor. Consult local or national electrical codes for switch requirements.
- Step 3. Disconnect power before servicing motor or pump. If the disconnect switch is out of sight of pump, lock it open and tag it to prevent unexpected power application.
- Step 4. Ground the pump permanently using a wire of the same size as that specified in wiring chart. Make ground connection to green grounding terminal under motor canopy marked GRD. or ⊕.
- Step 5. Connect ground wire to a grounded lead in the service panel or to a metal underground water pipe or well casing at least 10 feet long. Do not connect to plastic pipe or insulated fittings.

- Step 6. Protect current carrying and grounding conductors from cuts, grease, heat, oil, and chemicals.
- Step 7. Connect current carrying conductors to terminals L1 and L2 under motor canopy. When replacing motor, check wiring diagram on motor nameplate against Figure 3. If the motor wiring diagram does not match either diagram in Figure 3, follow the diagram on the motor.

IMPORTANT: 115/230 Volt single phase models are shipped from factory with motor wired for 230 volts. If power supply is 115 volts, remove motor canopy and reconnect motor as shown in Figure 3. Do not try to run motor as received on 115 volt current.

- Step 8. Motor has automatic internal thermal overload protection. If motor has stopped for unknown reasons, thermal overload may restart it unexpectedly, which could cause injury or property damage. Disconnect power before servicing motor.
- Step 9. If this procedure or the wiring diagrams are confusing, consult a licensed electrician.

Wiring Chart – Recommended Wire and Fuse Sizes

Motor HP	Volts	Max. Load Amp	Branch Fuse Rating Amp	DISTANCE IN FEET(METERS) FROM MOTOR TO SUPPLY				
				0 - 100 (0 - 30)	101 - 200 (31 - 61)	201 - 300 (62 - 91)	301 - 400 (92 - 122)	401 - 500 (123 - 152)
				AWG WIRE SIZE (mm ²)				
1/2	115/230	9.4/4.7	15/15	14/14 (2/2)	10/14 (5.5/2)	10/14 (5.5/2)	6/14 (14/2)	6/12 (14/3)
3/4	115/230	12.2/6.1	20/15	12/14 (3/2)	10/14 (5.5/2)	8/14 (8.4/2)	6/12 (14/3)	6/12 (14/3)
1	115/230	14.8/7.4	20/15	12/14 (3/2)	8/14 (8.4/2)	6/14 (14/2)	6/12 (14/3)	4/10 (21/5.5)
1-1/2	115/230	19.2/9.6	30/15	10/14 (5.5/2)	8/14 (8.4/2)	6/12 (14/3)	4/10 (21/5.5)	4/10 (21/5.5)
2	115/230	24.0/12.0	30/15	10/14 (5.5/2)	6/14 (14/2)	6/12 (14/3)	4/10 (21/5.5)	4/10 (21/5.5)

SYMPTOM	POSSIBLE CAUSE(S)	CORRECTIVE ACTION
Failure to pump	Pump not properly primed	Make sure pump casing and suction line are full of water. See priming instructions
Reduced capacity and/or pressure	Air pockets or leaks in suction line Clogged impeller	Check suction piping Remove and clean
Pump loses prime	Air leaks in suction line Excessive suction lift and operating too near shut-off point Water level drops while pumping, uncovering suction piping	Check suction piping Move pump nearer water level Check water supply. Add length of pipe to suction to keep submerged end under water
Mechanical troubles and noises	Bent shaft and/or damaged bearings Suction and/or discharge piping not properly supported and anchored	Take motor to authorized motor repair shop See that all piping is supported to relieve strain on pump assembly

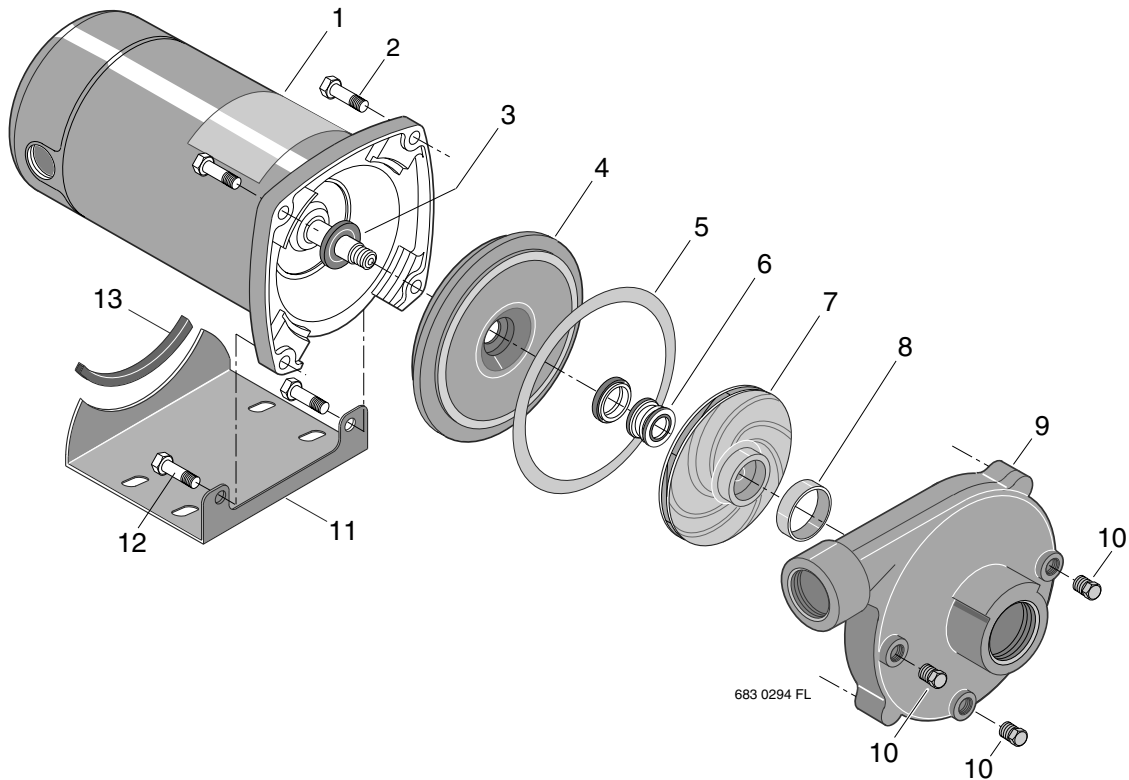

Repair Parts List

Key No.	Part Description	Qty.	FP5512-08 1/2 HP	FP5522-08 3/4 HP	FP5532-08 1 HP	FP5542-08 1-1/2 HP	FP5552-08 2 HP
1	Motor - 115/230V, 60 Cycle - Single Phase	1	A100CLL	A100DLL	A100ELL	A100FLL	A100GSL
2	Capscrew - 3/8 - 16 x 1-1/4" Lg.	2	U30-75ZP	U30-75ZP	U30-75ZP	U30-75ZP	—
2	Capscrew - 3/8 - 16 x 1" Lg.	2	—	—	—	—	U30-74ZP
3	Waster Slinger	1	17351-0009	17351-0009	17351-0009	17351-0009	17351-0009
4	Seal Plate	1	C3-178	C3-178	C3-178	C3-178	C3-181
5	Gasket	1	C20-121	C20-121	C20-121	C20-121	C20-122
6	Shaft Seal	1	U109-6A	U109-6A	U109-6A	U109-6A	U109-6A
7	Impeller	1	C105-92PN	C105-92PM	C105-92PL	C105-92PB	C105-214PCA
8	Wear Ring	1	C23-27	C23-27	C23-27	C23-27	C23-19
9	Volute Assembly - With Wear Ring	1	C101-284E	C101-284E	C101-284E	C101-284E	C101-264E
10	Pipe Plug - 1/4" NPT, Hex Head	3	U78-941ZPV	U78-941ZPV	U78-941ZPV	U78-941ZPV	U78-941ZPV
11	Base - With Motor Pad	1	J204-9	J204-9	J204-9	J204-9	J104-9
12	Capscrew - 3/8 - 16 x 1-1/2" Lg.	2	U30-76ZP	U30-76ZP	U30-76ZP	U30-76ZP	—
12	Capscrew - 3/8 - 16 x 1-1/4" Lg.	2	—	—	—	—	U30-75ZP
13	Motor Pad	1	C35-5	C35-5	C35-5	C35-5	C35-5